

QUASER

we cut faster

HX805 SERIES



QUASER
we cut faster

HX 805

HX
6.00

Work

Ø1,200 mm x 1,100 mm x 1,500 kg



2+2 Concept and rigid frame structure to achieve high speed and heavy cutting performance.

Static rigidity

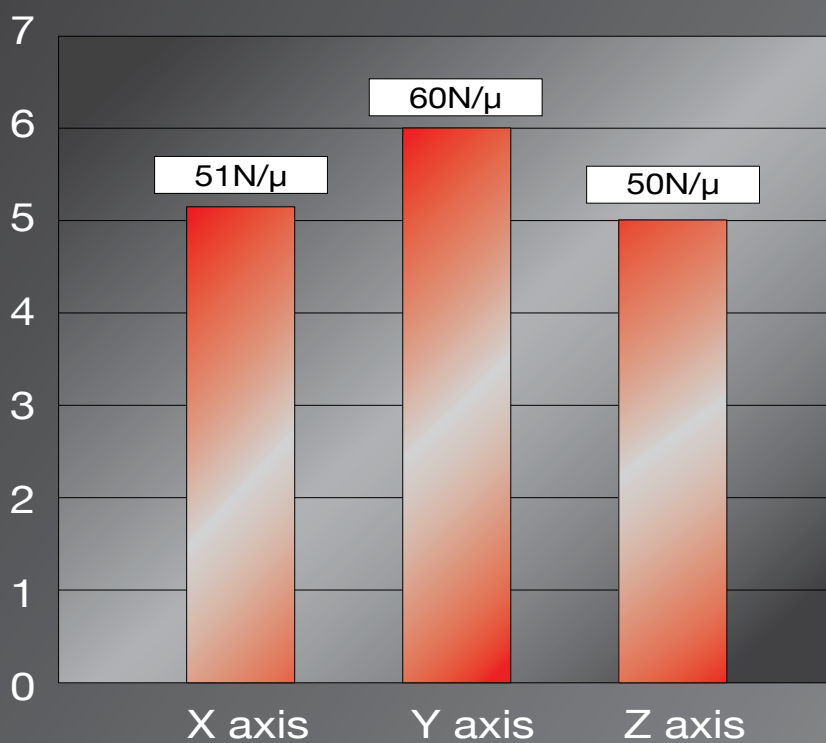

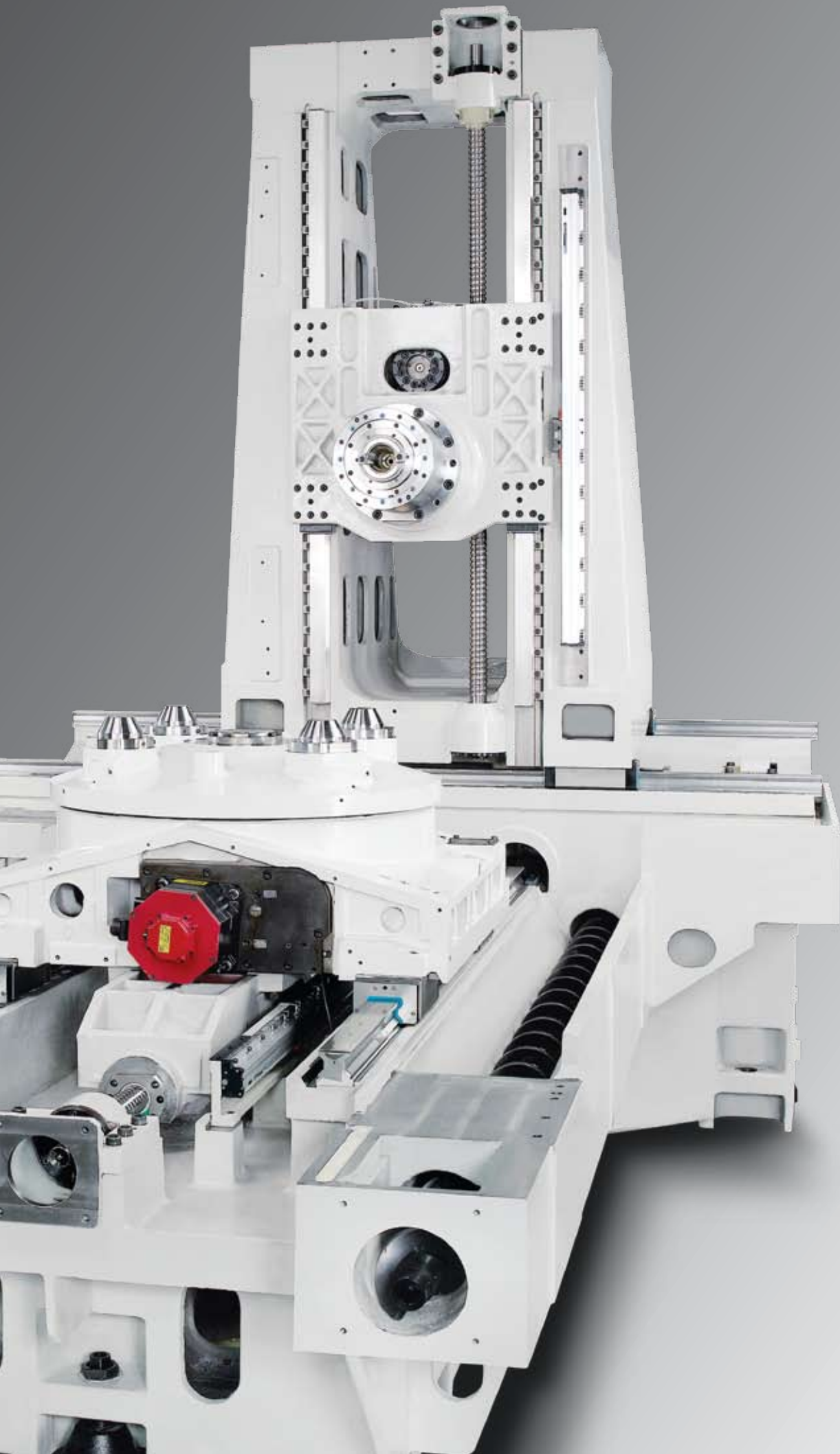

Ball screw : Ø 50 x 16 mm

Linear guide : #65 roller

Linear scale : (std.) Absolute 0.05 µm

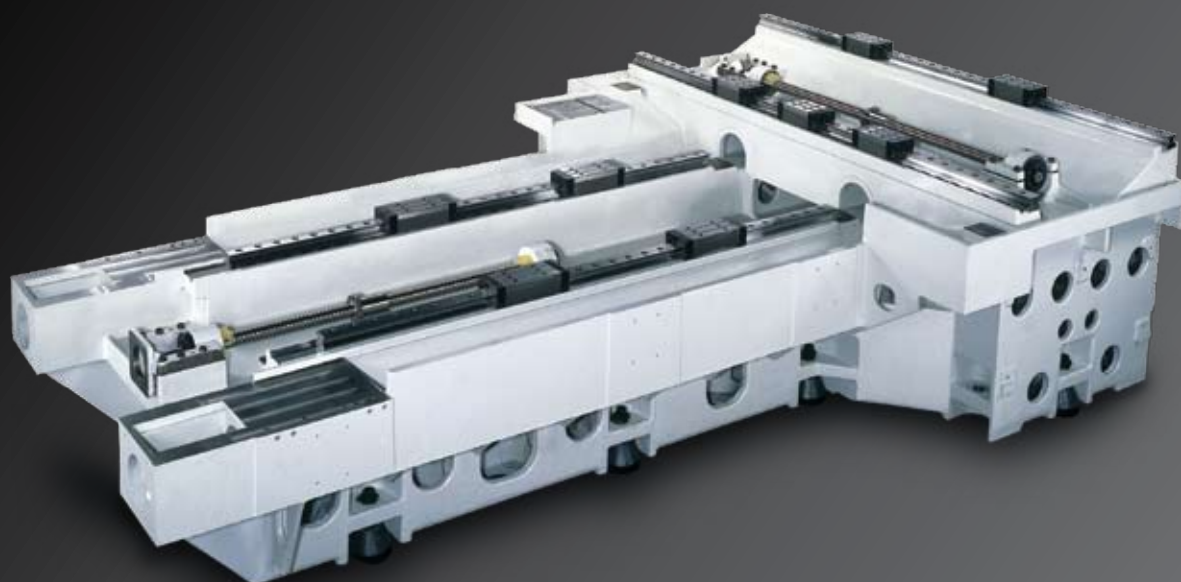

One piece cast iron base at 9 tons

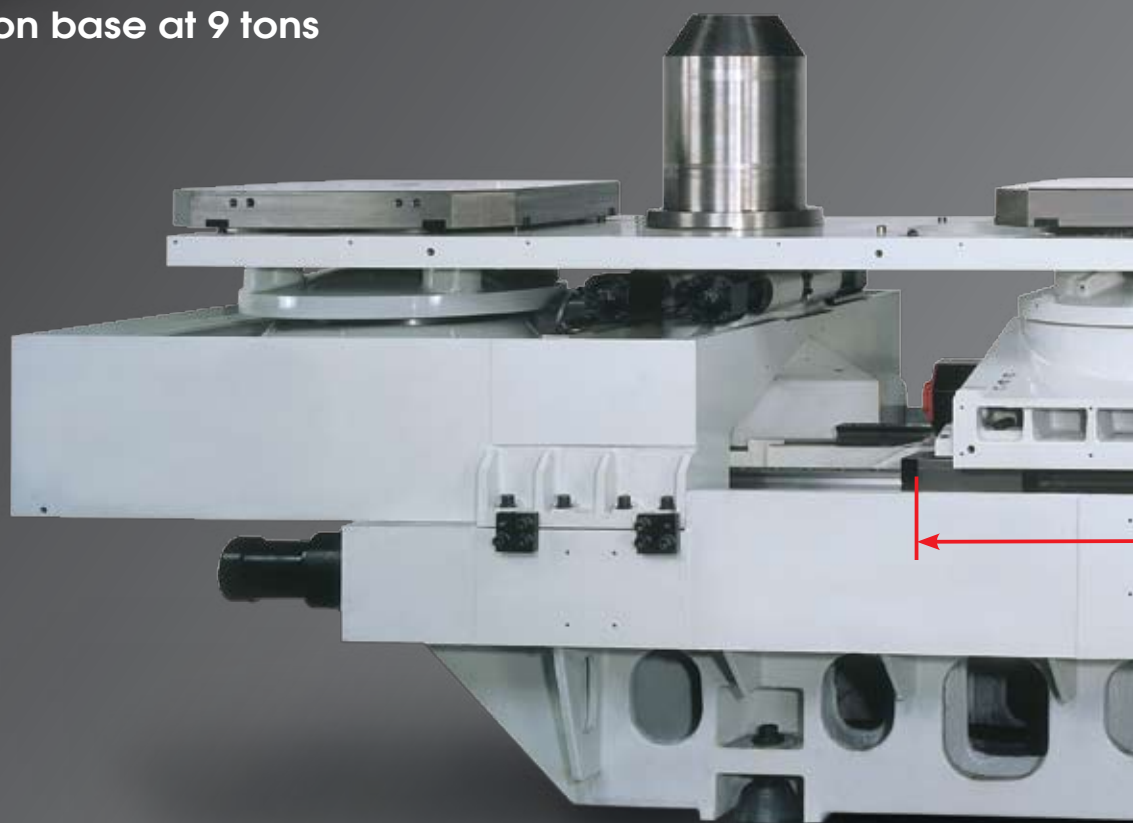

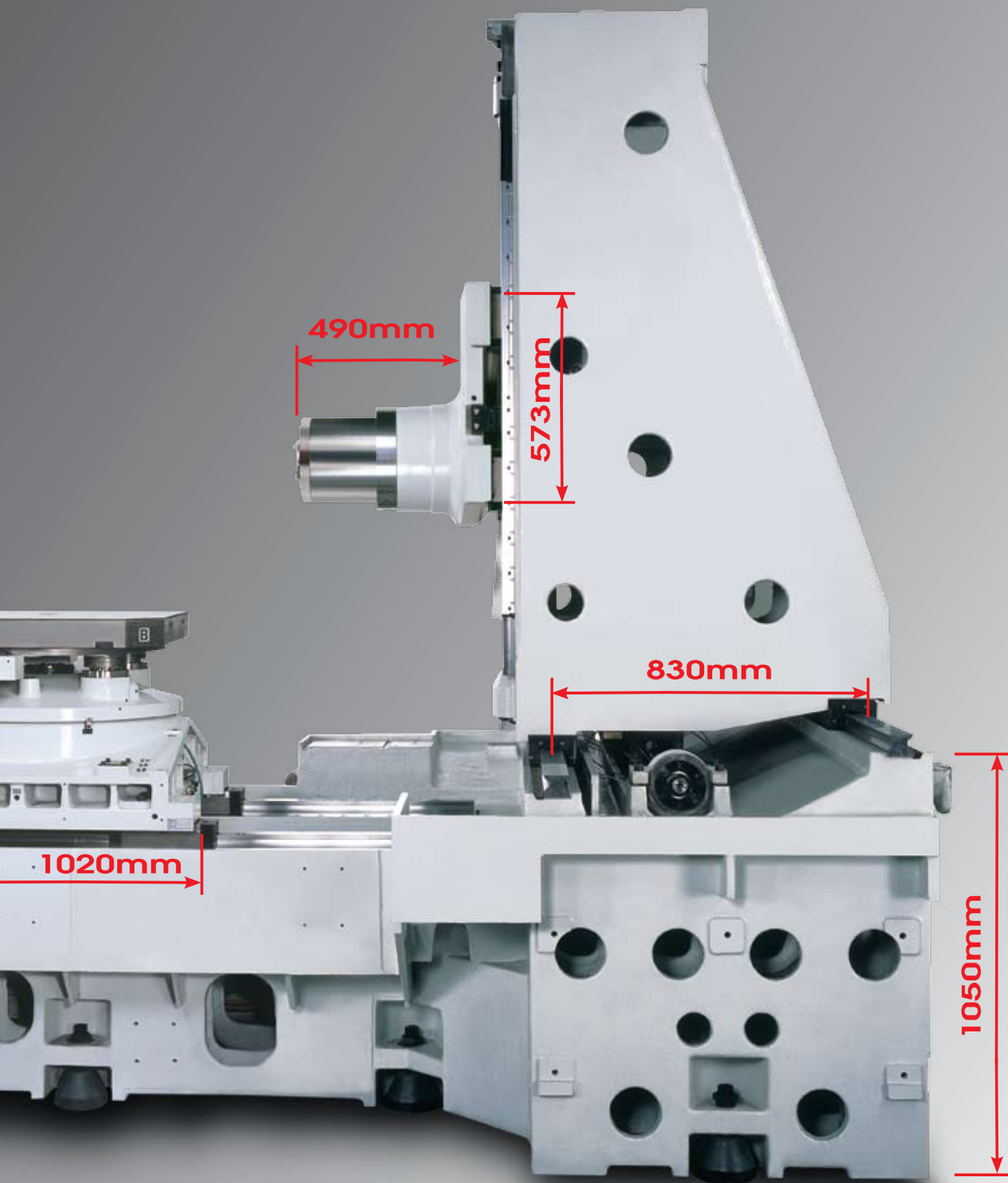

Direct axes transmission

Motor:

X : 7 KW

Y : 6 KW

Z : 7 KW

Rapid:

X / Y / Z: 40 m/min

Acceleration:

X : 4 m/s²

Y : 5 m/s²

Z : 5 m/s²



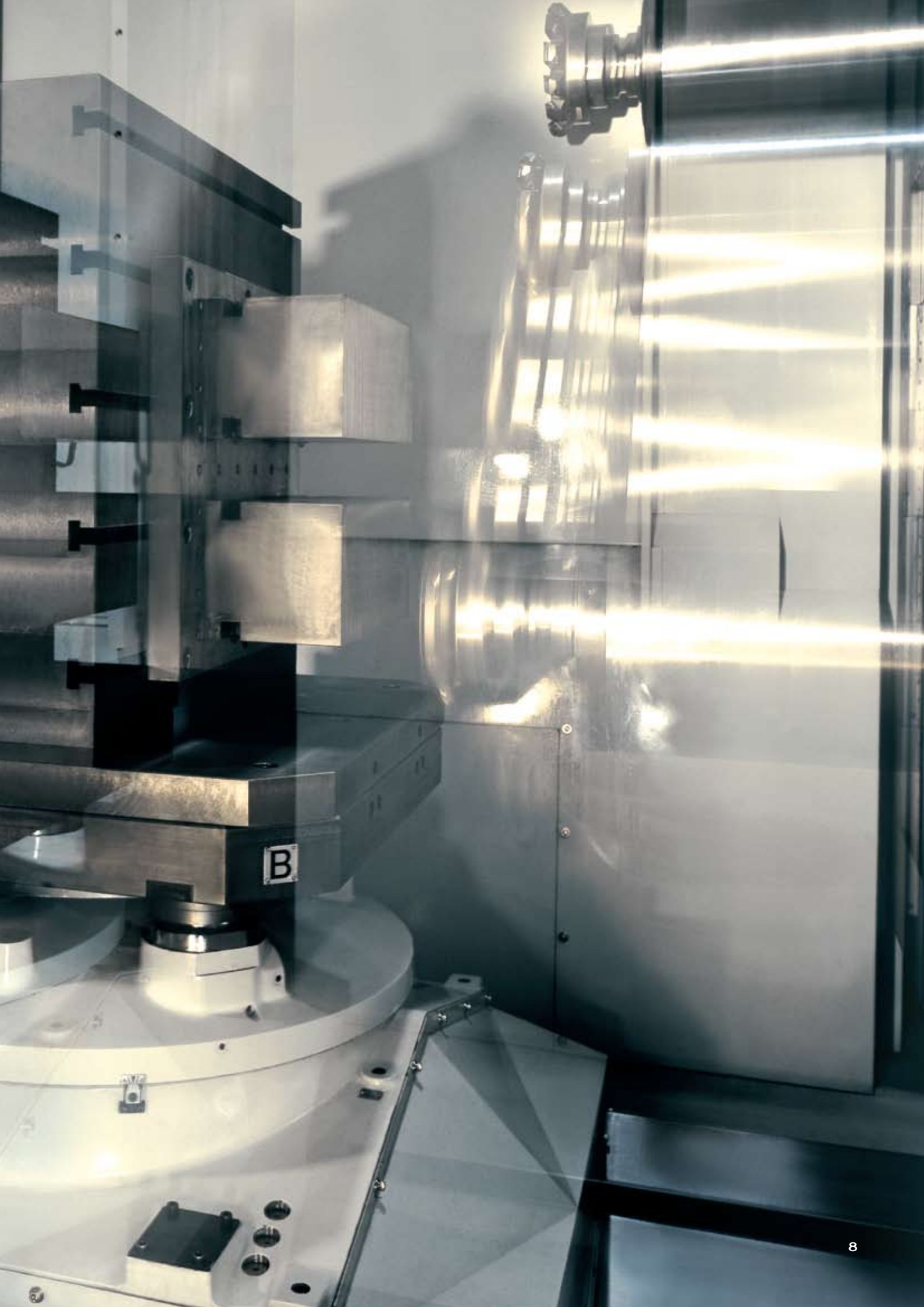

Type NB50 high torque spindle (955 Nm) for model “HT” through most reliable ZF gear box

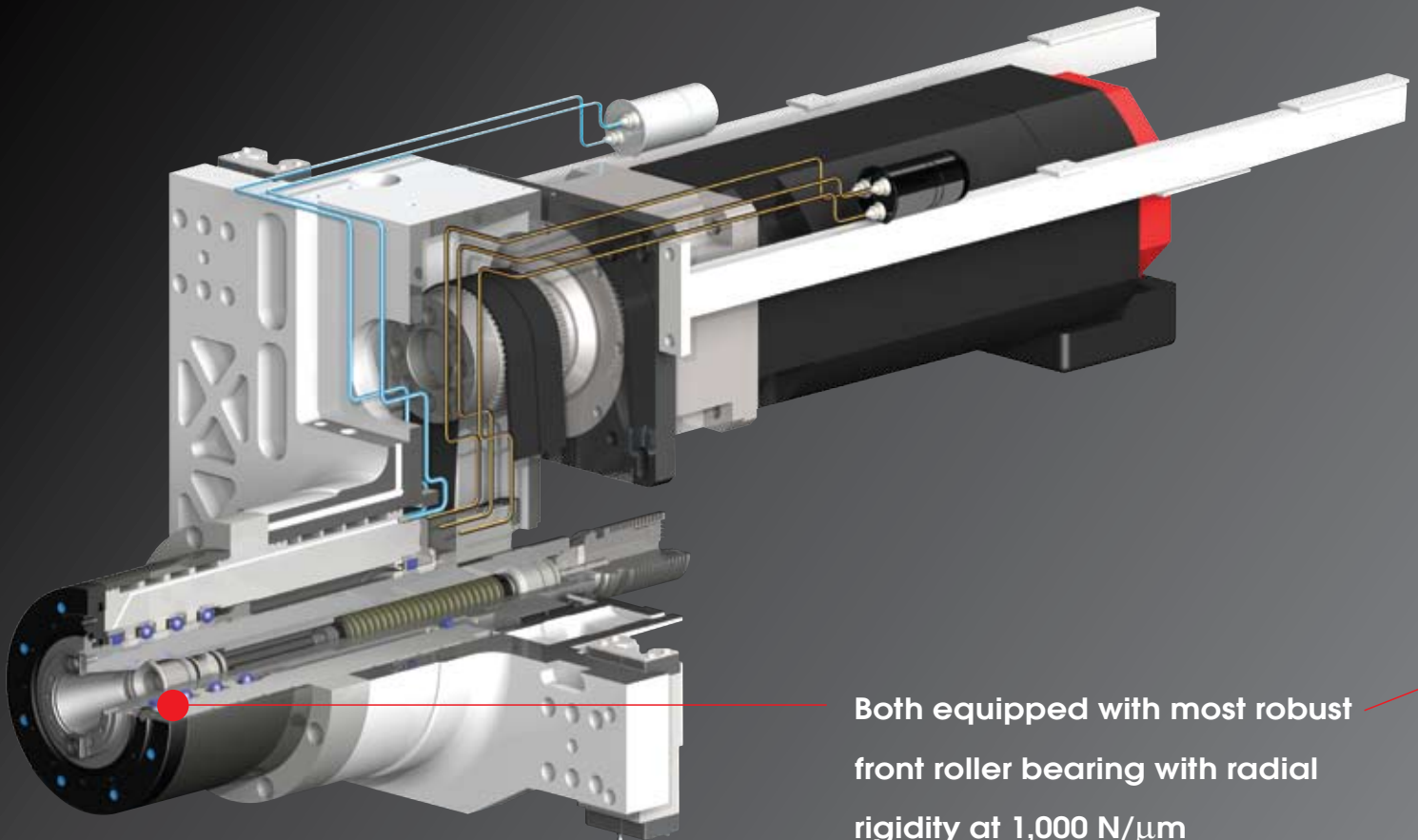

Both equipped with most robust front roller bearing with radial rigidity at 1,000 N/ μ m
- Best in this class

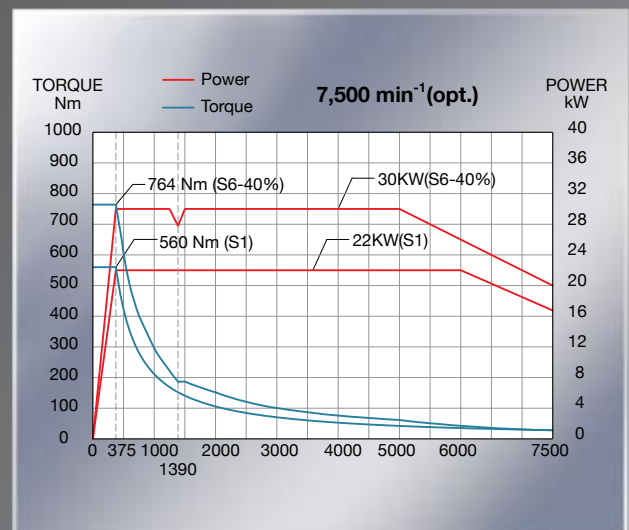
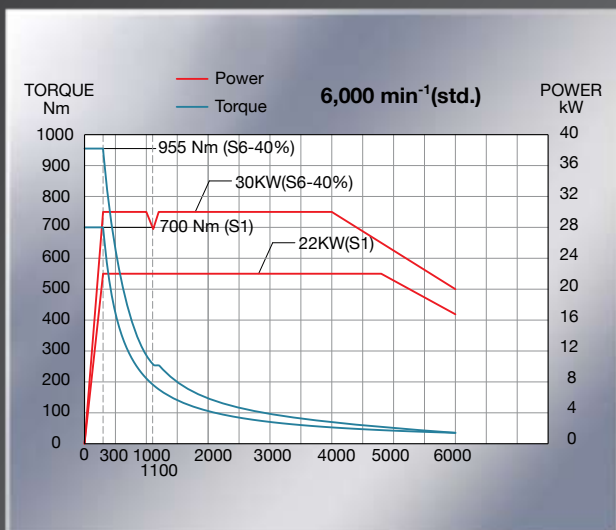

Type NC50 high speed / high power spindle for model "HS" through direct coupling

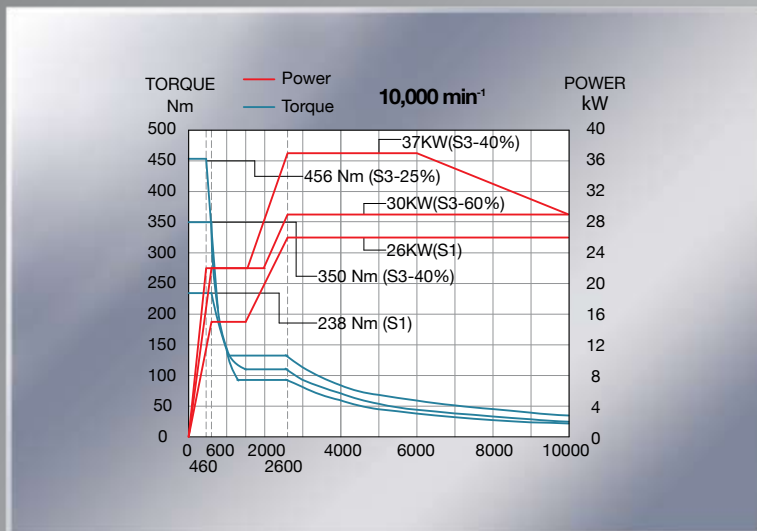
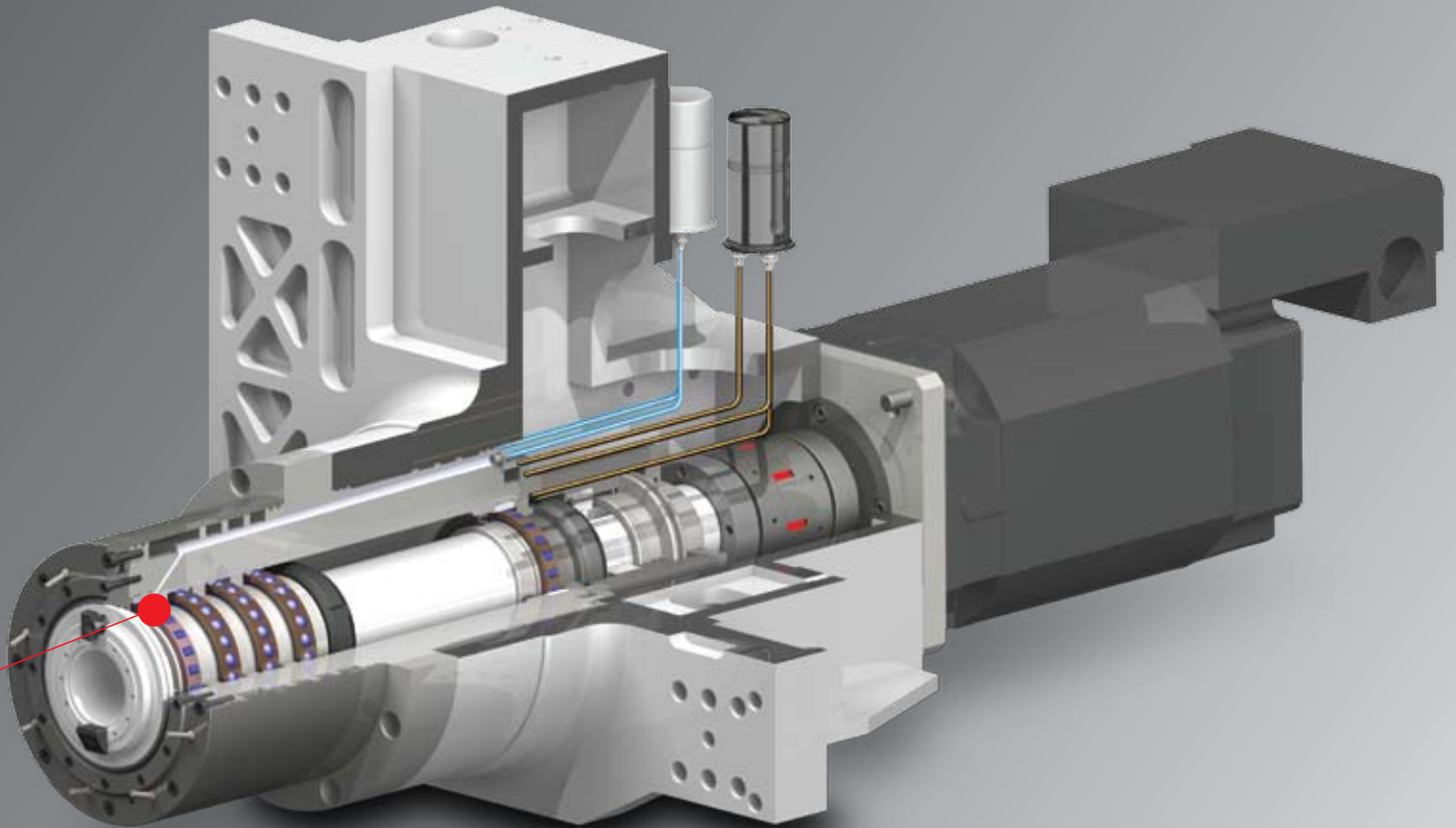

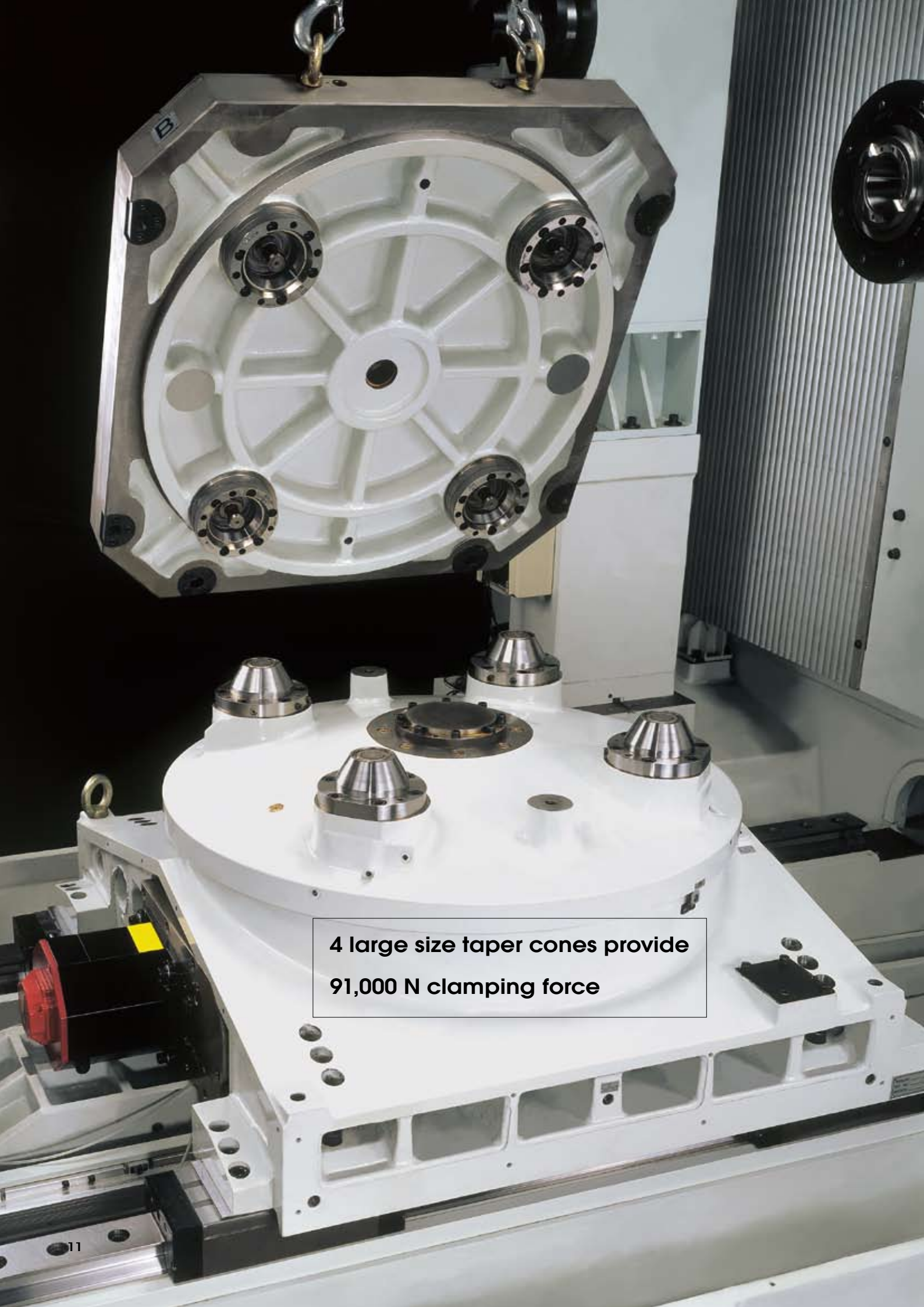

4 large size taper cones provide
91,000 N clamping force

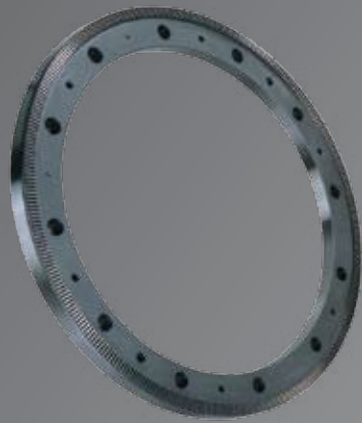

Indexing table (1°)

Pallet size: 800 x 800 mm

Accuracy: ± 3 sec

Large tooth coupling: $\varnothing 700$

Tilting moment: 28,000 Nm

High clamping force: 90,000 N.



NC rotary table (0.001°)

Pallet size: 800 x 800 mm

Rotary encoder: ± 5 sec

Tilting moment: 19,000 Nm

Clamping torque: 5,635 Nm

Drive torque: 3,200 Nm

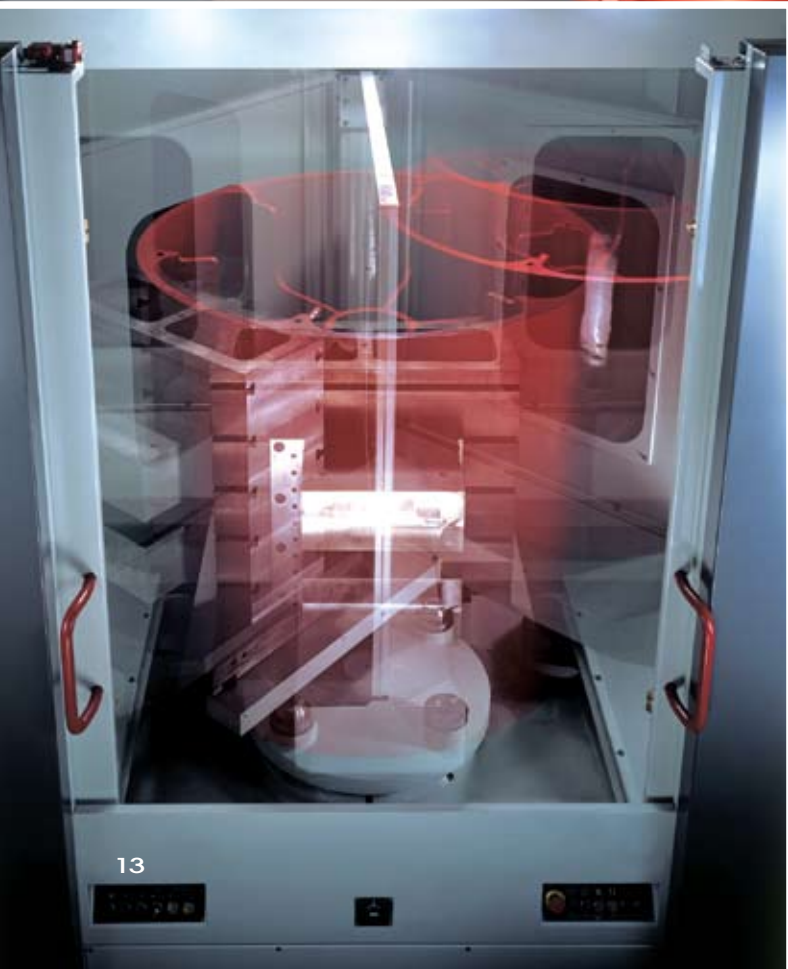
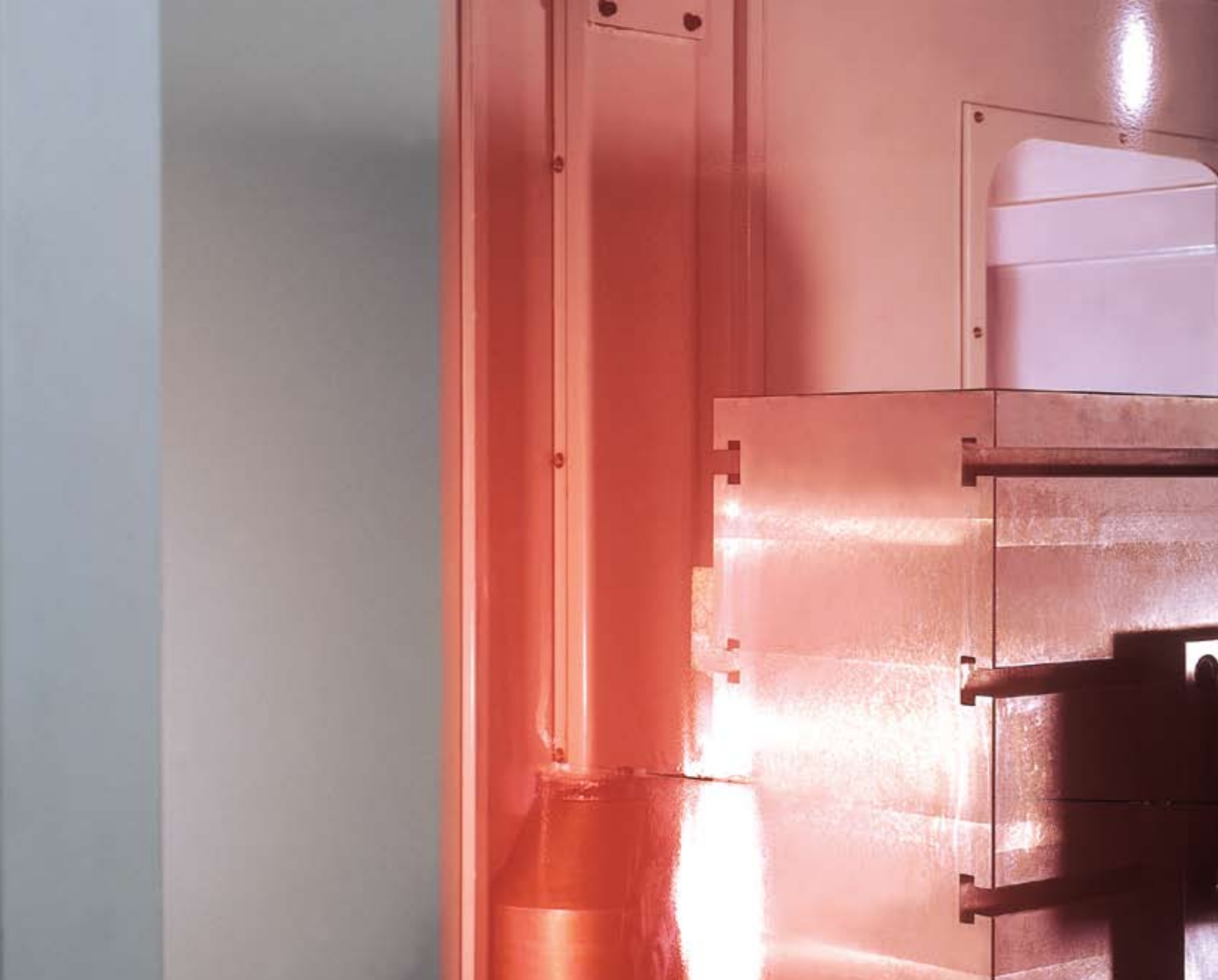



Pallet change time: 15 sec.

Pallet changing repeatability: 0.015mm

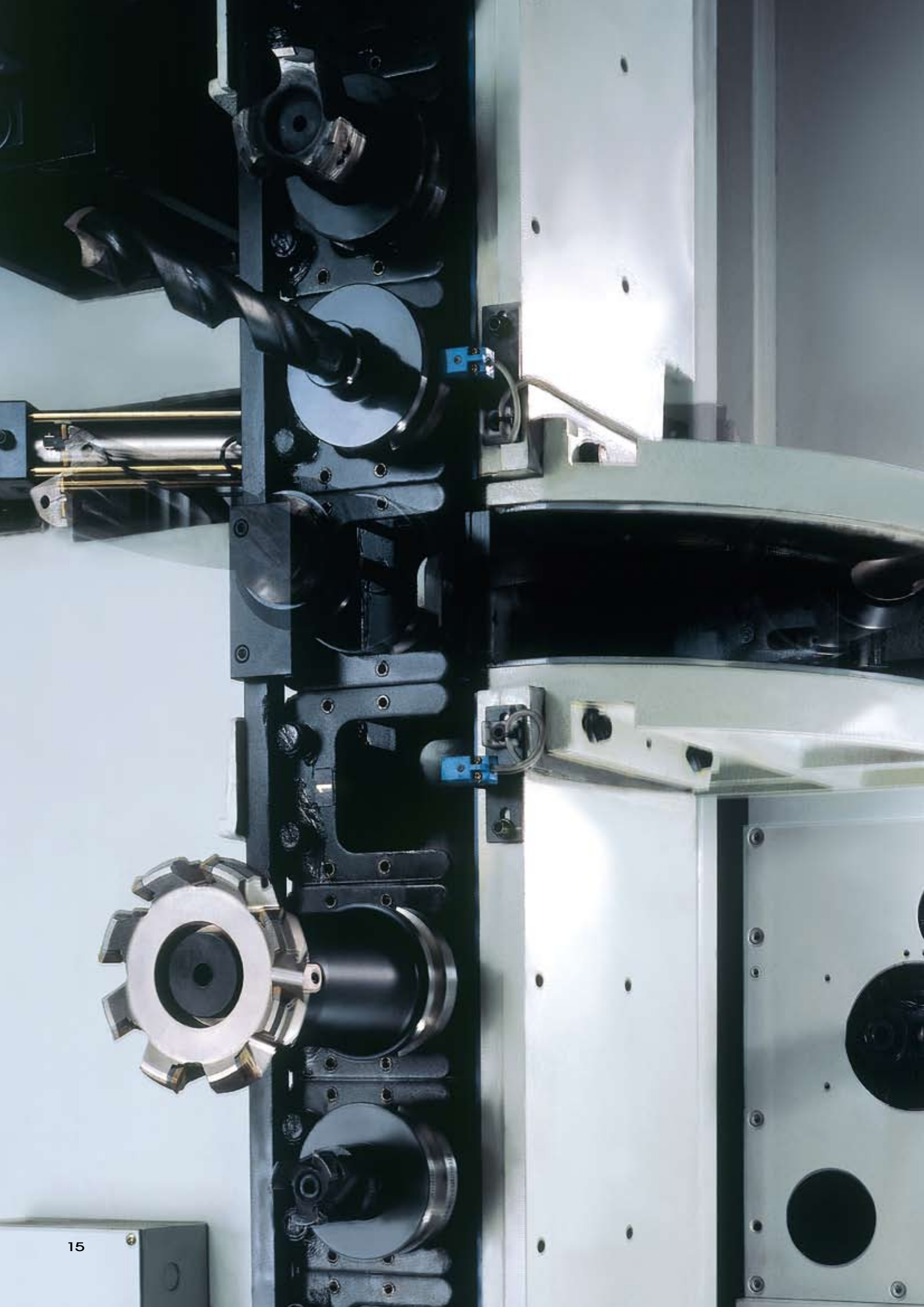

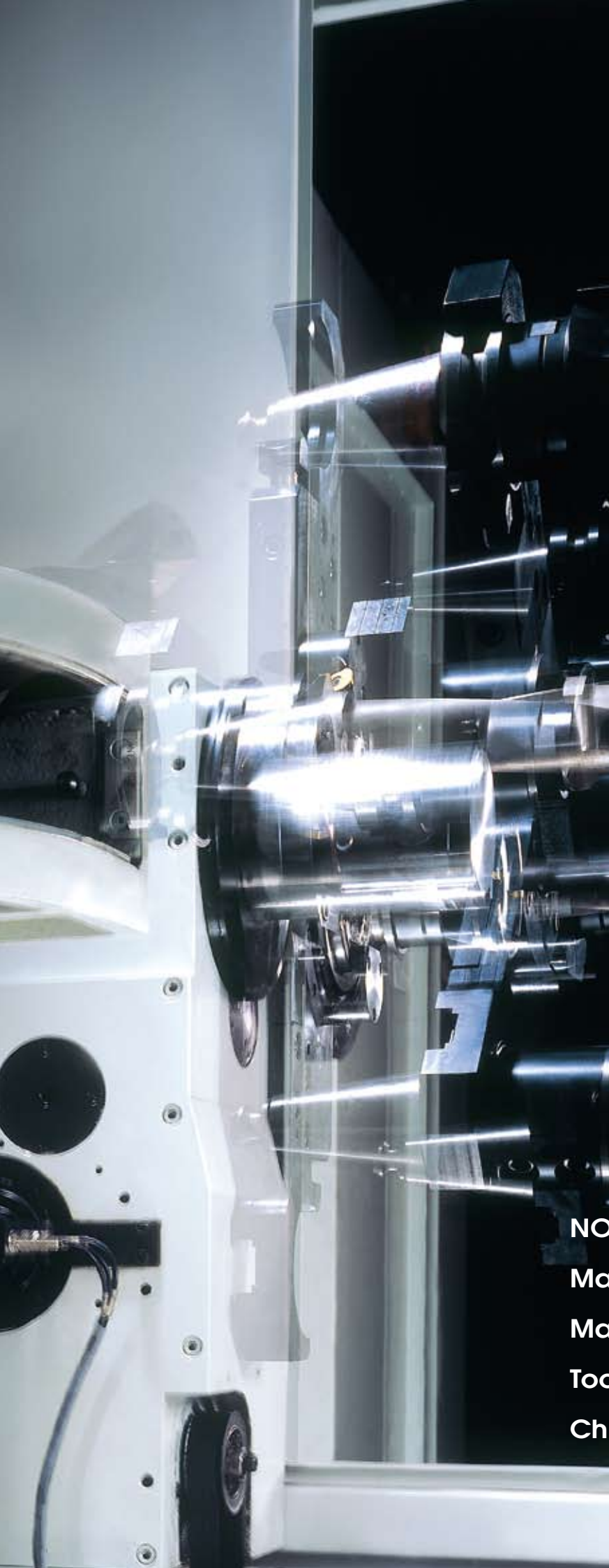

NO.50 / 60 pos.

Max. tool length: 600 mm

Max. tool weight: 25 kg

Tool to tool time: 3.5 sec.

Chip to chip time: 7 sec.

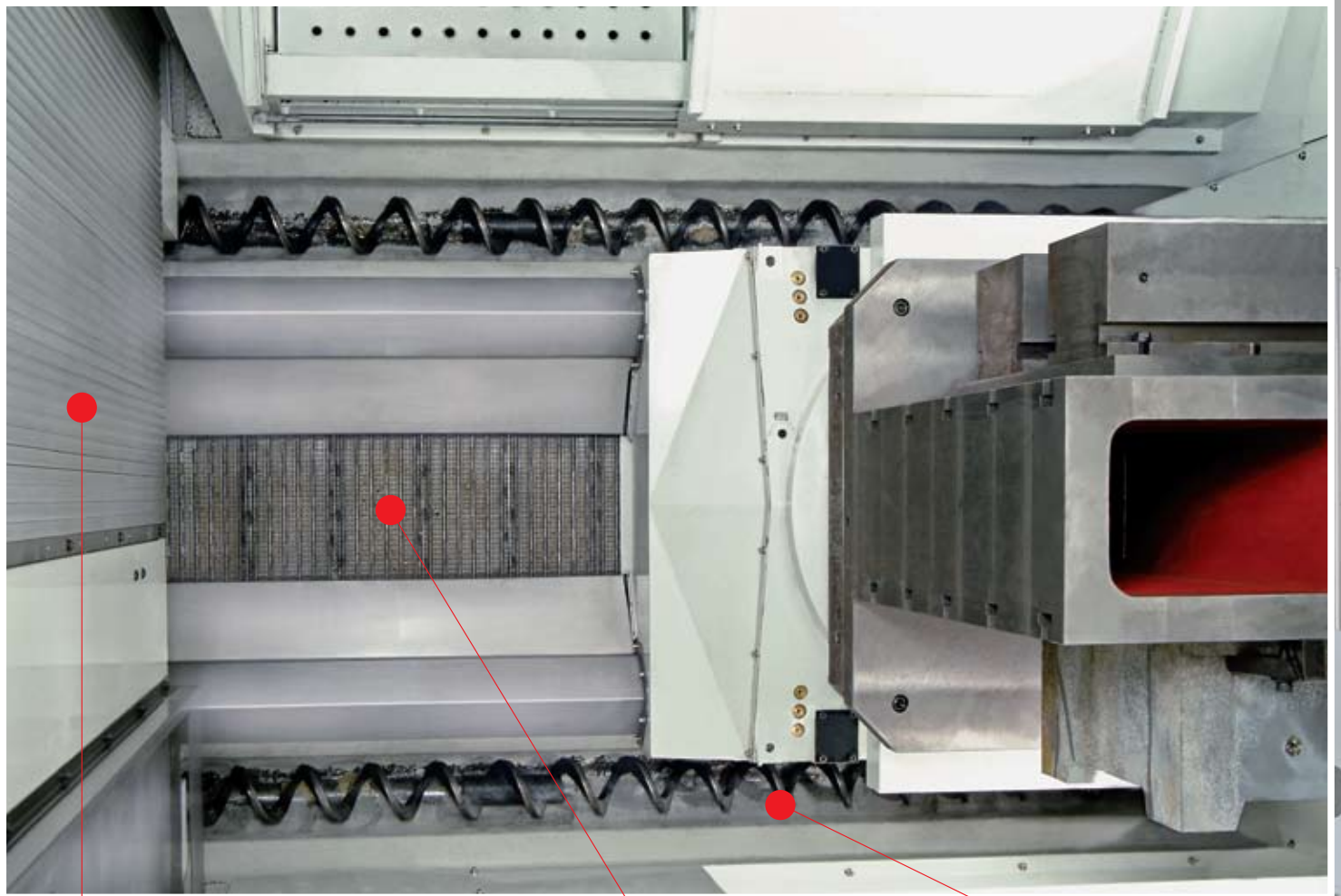

**Apron type X way cover
(8mm thick aluminum strip)**

Center chip conveyor

Dual augers

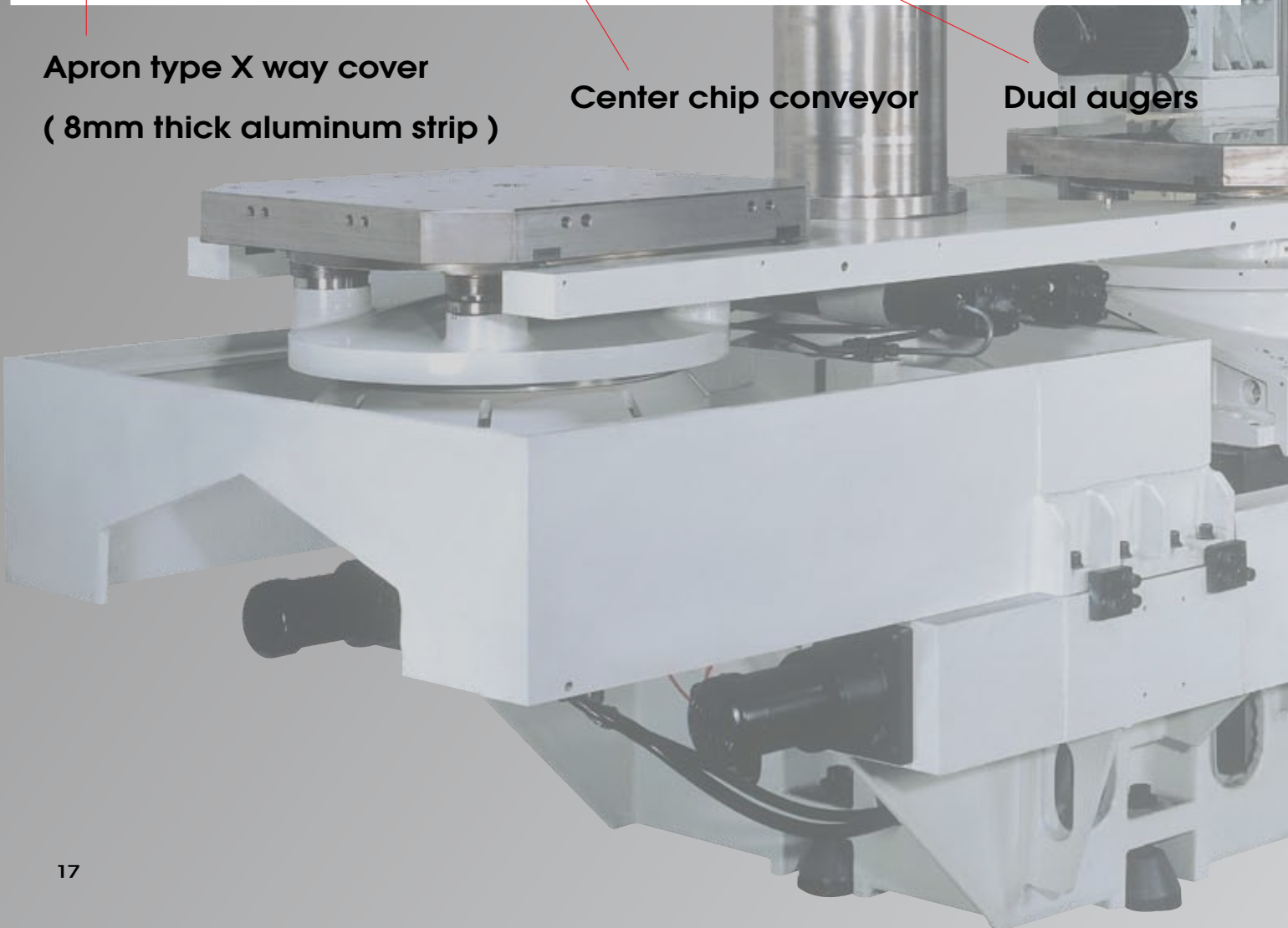

Total solution on chip management





1,200 liter coolant tank with

- A** Coolant through spindle : 20 bar
- B** Spindle nozzle coolant : 4 bar
- C** Ceiling wash down : 1.5 bar
- D** Dual wash guns for operation and loading / unloading side : 4 bar





User friendly



Large door opening for settings



**Swivel type
operation panel**



Tool loading /
unloading
on magazine
side

Centralized maintenances



Cutting data : 6,000 min⁻¹

Workpiece material Ductile cast iron (FCD450)
Tool used 200 mm dia. face mill
Spindle speed 320 min⁻¹
Feedrate 1,280 mm/min
Depth/width of cut 4 / 175 mm

Metal removal rate: 896 cm³/min



Workpiece material Ductile cast iron (FCD450)
Tool used 125 mm dia. face mill
Tool length 210 mm
Spindle speed 630 min⁻¹
Feedrate 1,320 mm/min
Machining in upper range of the Y-axis
Depth/width cut 4 / 100 mm

Metal removal rate: 528 cm³/min

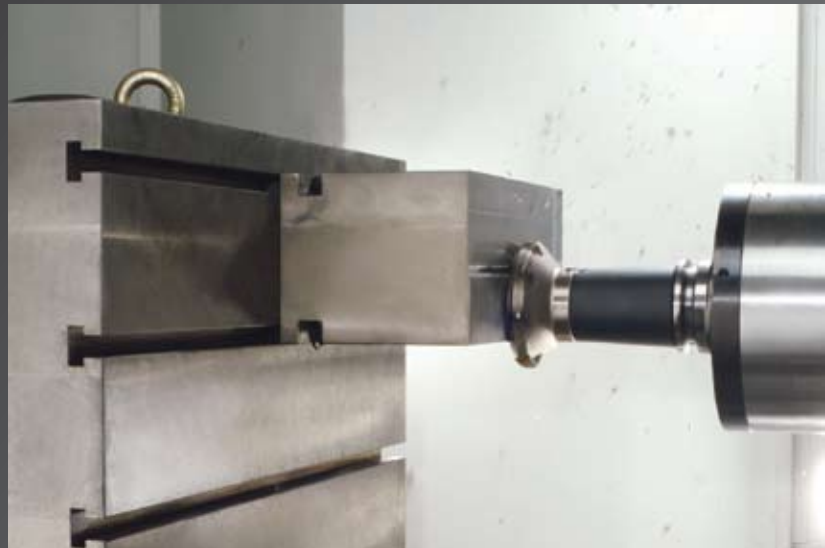

Workpiece material Ductile cast iron (FCD450)
Tool used 80 mm dia. face mill
Tool length 275 mm
Spindle speed 800 min⁻¹
Feedrate 1,440 mm/min
Depth/width of cut 4 / 60 mm

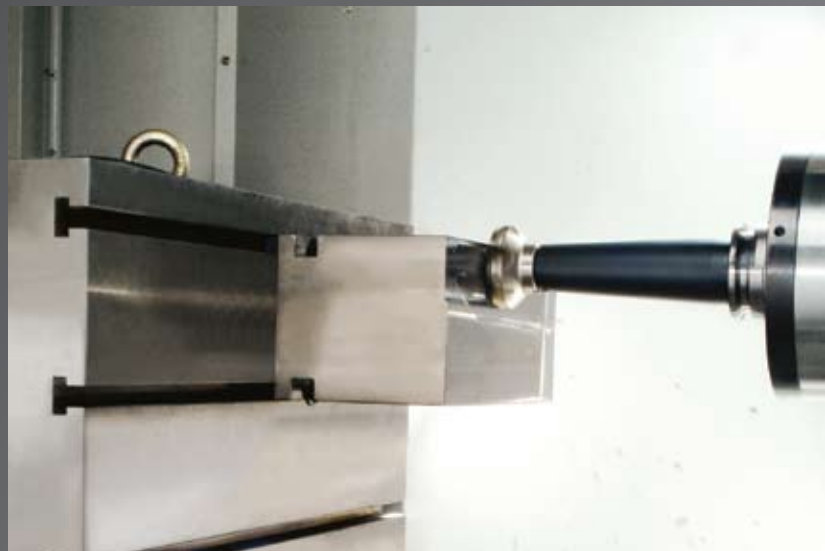

Workpiece material Ductile cast iron (FCD450)
Tool used 150 mm dia.
 staggered tooth side milling
 cutter (16-insert)
Tool length 170 mm
Spindle speed 95 min⁻¹
Feedrate 152 mm/min
Depth/width of cut 4 / 15 mm





Workpiece material	Ductile cast iron (FCD450)
Tool used	40 mm dia. end mill
Spindle speed	1,200 min ⁻¹
Feedrate	480 mm/min
Depth/width of cut	6 / 50 mm



Workpiece material	Ductile cast iron (FCD450)
Tool used	190 mm dia. boring
Tool length	465 mm
Spindle speed	167 min ⁻¹
Feedrate	67 mm/min
Stock removed	5.0 mm (one side)



Workpiece material	Ductile cast iron (FCD450)
Tool used	68 mm dia. Insert drill
Spindle speed	702 min ⁻¹
Feedrate	106 mm/min
Metal removal rate: 385 cm³/min	



Workpiece material	Ductile cast iron (FCD450)
Tool used	M42-4.5 tap
Spindle speed	76 min ⁻¹
Feedrate	342 mm/min
Spindle load	25%

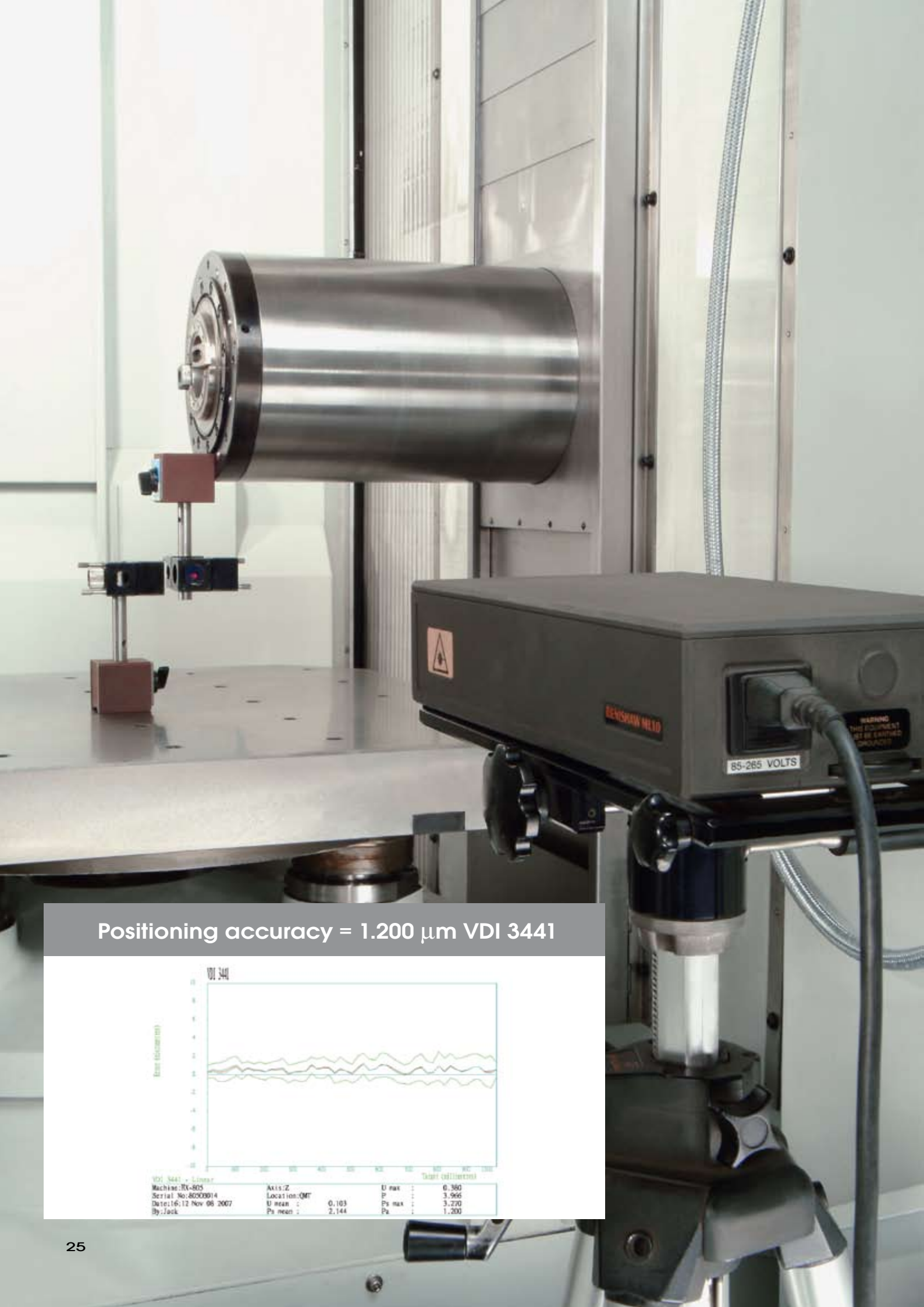

Positioning accuracy = 1.200 μm VDI 3441

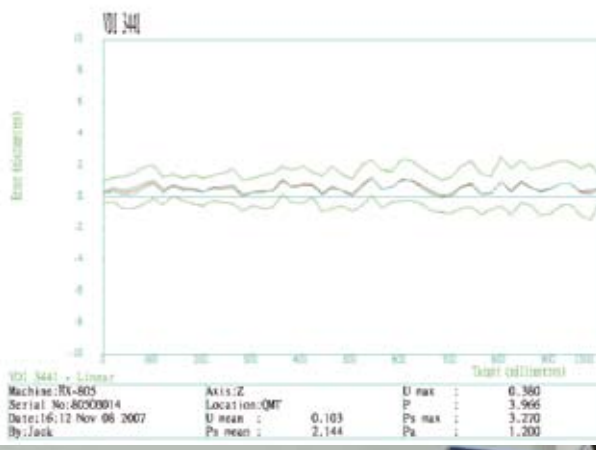



Double ball bar, Feedrate: 5,000 mm/min, Value: 4.4 μ m (ISO)

Circular Hysteresis

Value 4.4 μ m
Location 268.0°

Test Parameters

Radius 150.0000mm
Sample rate 125.0000HZ
Feedrate 5000.0mm/min
Run sequence CCW CW
Plane under test XY
Test position
Start angle 270°
End angle 270°
Overshoot angle 180°

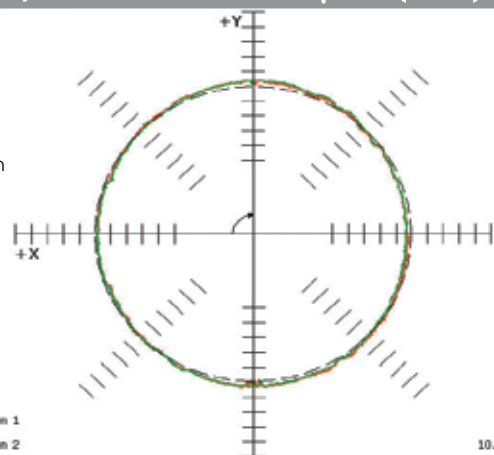

Run 1
Run 2

10.0 μ m/div

HX805 series

Technical data

Models

HX805	
A	B
1° B AXIS	FULL B AXIS

Technical data	HX805					
	A			B		
	HT	HS		HT	HS	
Work range						
Pallet size (mm)	800 x 800					
Max. work swing diameter (mm)	Ø1,200*					
Max. work piece height	1,100					
Table load capacity (kg)	1,500					
Travel X / Y / Z (mm)	1,200 / 1,000 / 1,000					
B minimum indexing (degree)	1			0.001		
Table surface to spindle center (mm)	30~1,030					
Spindle nose to table center (mm)	100~1,100					
Surface configuration	24-M16 Tapped holes; pitch:160					
Feed drive						
Feed force	X (N)	11,780				
	Y (N)	14,920				
	Z (N)	11,780				
Rapid movement	X / Y / Z (m/min)	40				
	B (sce. /90 degree)	3		2.1		
Acceleration	X / Y / Z (m/s ²)	4 / 5 / 5				
Dia. & pitch of the ball screw (mm)	Ø50 x 16					
Position accuracy						
With Linear encoder (ISO230-3/JIS)	0.008 / 0.004					
Main spindle – 50 Taper						
Spindle taper	BBT50					
Max. spindle speed	6,000	7,500 (Opt.)	10,000	6,000	7,500 (Opt.)	10,000
Spindle base speed	300	375	460 ⁽¹⁾	300	375	460 ⁽¹⁾
Spindle output kW / torque Nm (S6-40%)	30 / 955	30 / 764	37 / 456 ⁽²⁾	30 / 955	30 / 764	37 / 456 ⁽²⁾
Spindle Transmission	ZF Gear box + Belt		Coupling	ZF Gear box + Belt		Coupling
Spindle bearing diameter (mm)	Ø100					
Tool changer						
Tool selection	Address fixed, random method					
Magazine positions	60					
Max. tool diameter w/o adjacent tool (mm)	120 / 230					
Max. tool length (mm)	600					
Max. tool weight (kg)	25					
Max. tool weight moment <form spindle gauge line> (Nm)	50					
Tool to tool time (sec.)	3.5					
Chip to chip time (sec.)	7					
Pallet changer						
Number of pallet	2					
Method of pallet changer	ARM type					
Pallet change time (sec.)	15					
Pallet changing repeatability (mm)	0.015					
Coolant system						
Coolant tank capacity (Liter)	1,200 L					
- Nozzle coolant pump capacity	60 L / min, 4 bar					
- Through spindle coolant pump capacity	25 L / min, 20 bar					
- Celling wash down pump capacity	200 L / min, 1.5 bar					

Note: *Maximum swing diameter Ø1,000, due to tool length measurement option is select.

Main spindle

50 Taper Gear box /6= 6,000 min⁻¹ (standard)
 /7.5= 7,500 min⁻¹ (option)
 50 Taper coupling /10= 10,000 min⁻¹ (high speed)

Control

FANUC 18iM-B

Technical data	HX805			
	A		B	
	HT	HS	HT	HS
Machine size				
Height (mm)	3,610			
Floor space W x D (mm)	3,780 x 7,900			
Weight (kg)	25,000			
Connections				
Main power	220 V / 60 Hz or 400 V / 50 Hz			
Power consumption (KVA)	70			

Note: ^①S3-40% ^②S3-25%

● = Standard ○ = Option × = N / A

Standard / Option accessories	HX805	
	A	B
■ FANUC 18iM-B	●	●
■ Spindle oil chiller	●	●
■ 60 position tool magazine	●	●
■ 120 position tool magazine	○	○
■ Pull stud for BT tooling (QUASER supply)	○	○
■ Pull stud for DIN tooling (69872-A)	○	○
■ Pull stud for ISO tooling (7388-B)	●	●
■ 2 pallet station	●	●
■ NC rotary table (0.001°) with rotary encoder	×	●
■ Linear encoder (Absolute 0.05 μm)	●	●
■ Tool length / breakage measurement (BLUM)	○	○
■ Coolant system	●	●
■ 20 bar through spindle coolant	●	●
■ 50 bar through spindle coolant	○	○
■ Ceiling wash down coolant	●	●
■ Base, wash down coolant	●	●
■ Coolant wash gun (2 sets)	●	●
■ Chip augers (2 sets)	●	●
■ Internal chip conveyor (scraper type)	●	●
■ Internal chip conveyor (hinge type)	○	○
■ External chip conveyor (hinge type)	●	●
■ External chip conveyor (with drum filter)	○	○
■ Work light	●	●
■ Machine status light	●	●
■ CE & EMC	●	●

Pallet dimension

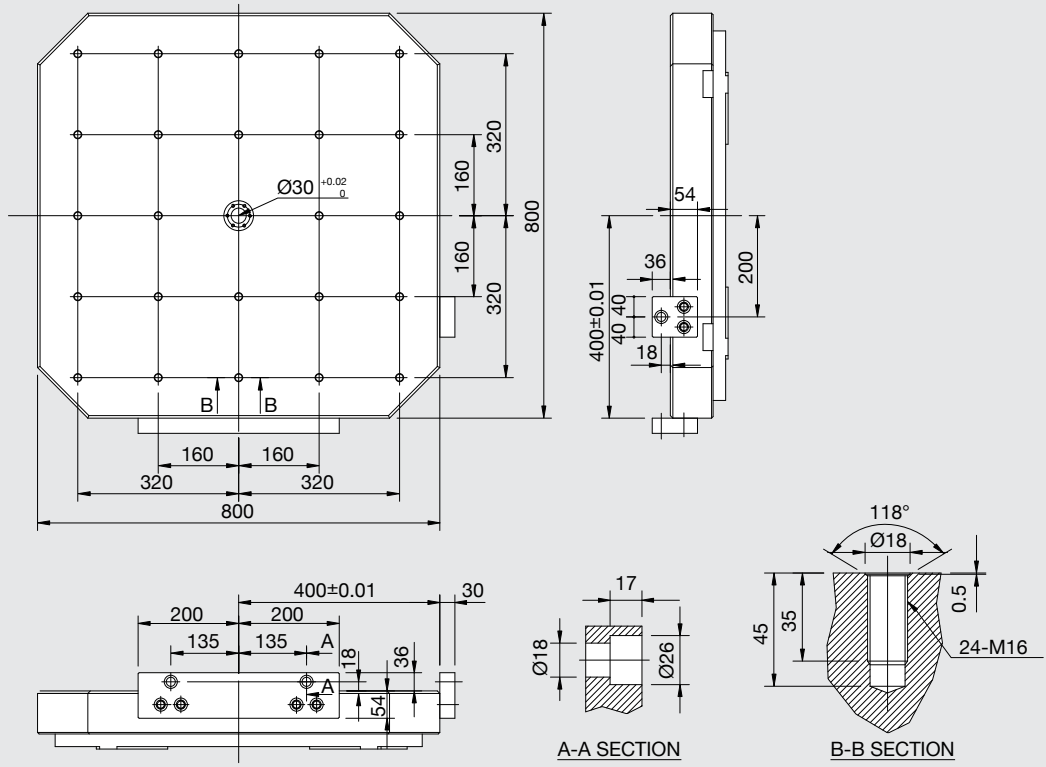

Cutting area interference

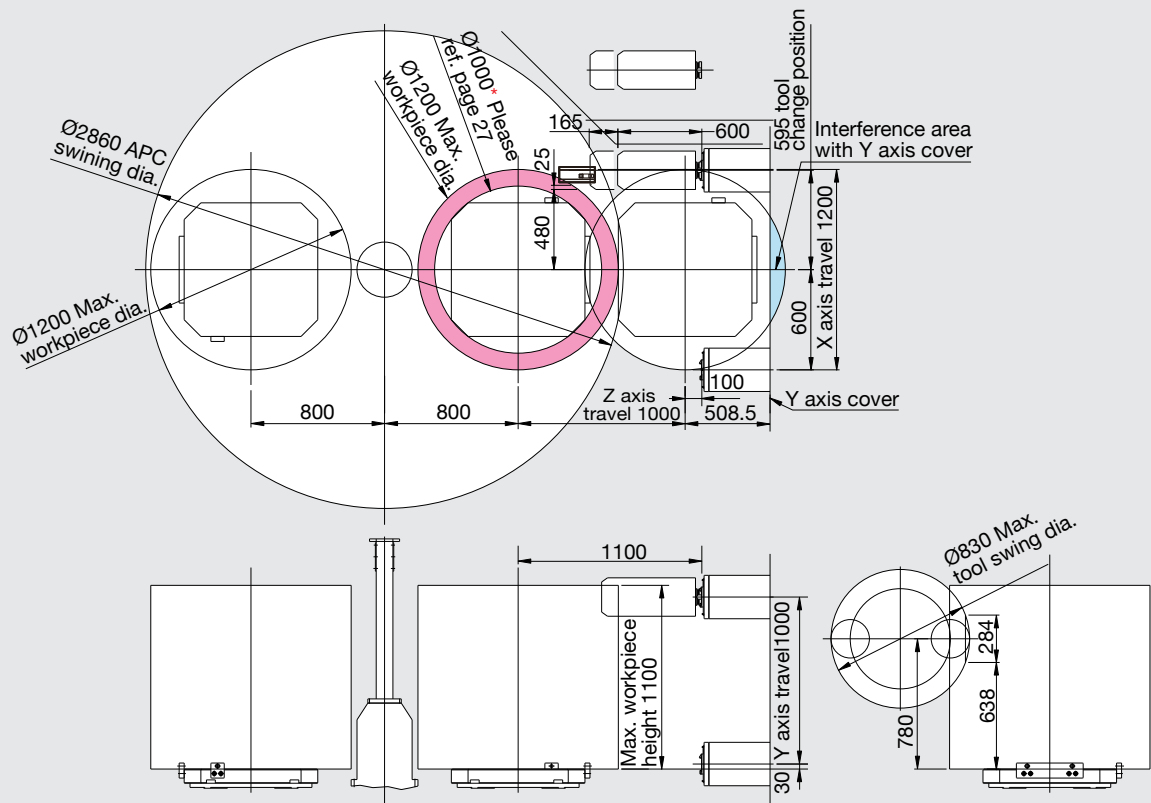

Installation dimension

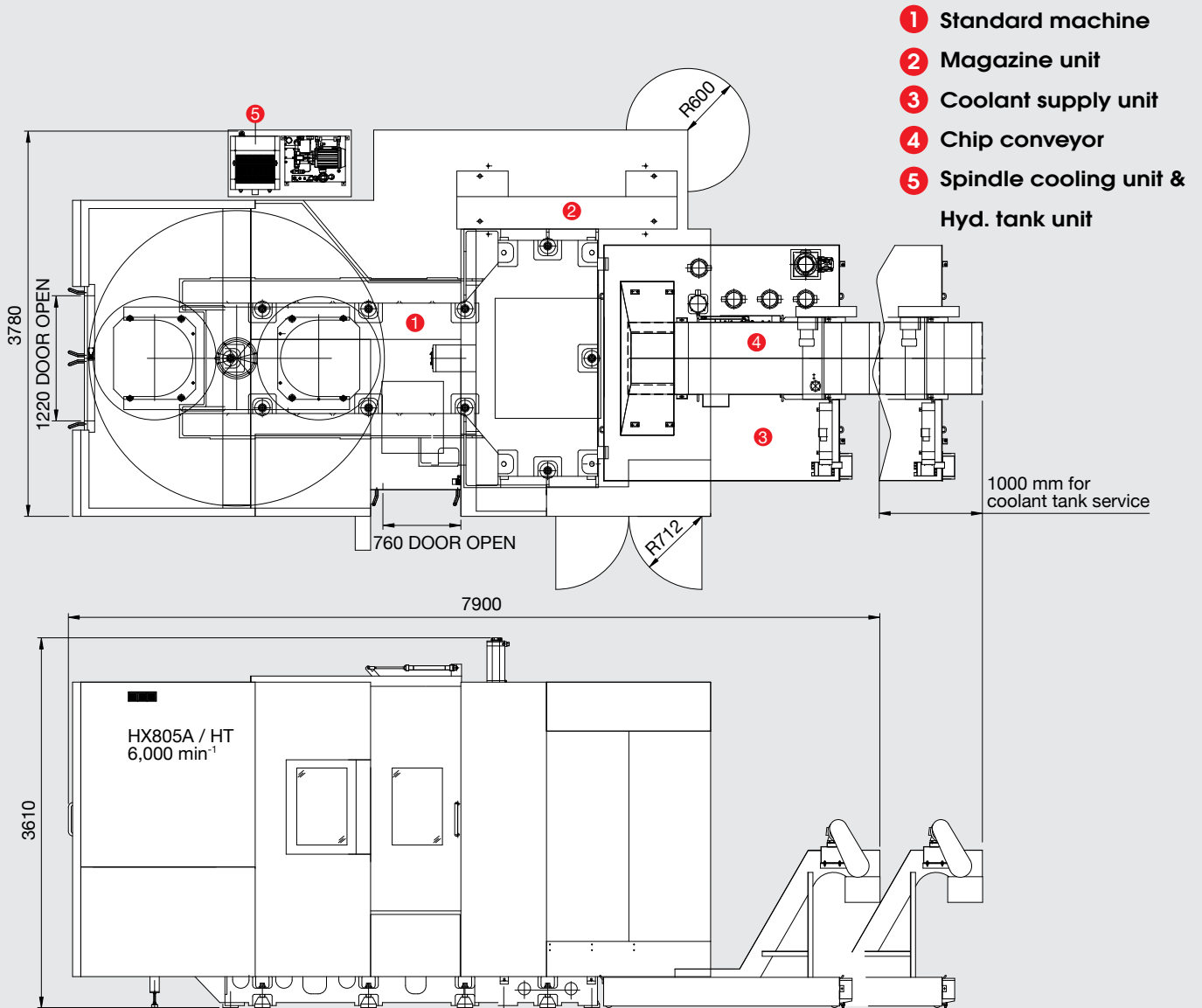

Pull stud and applicable tools

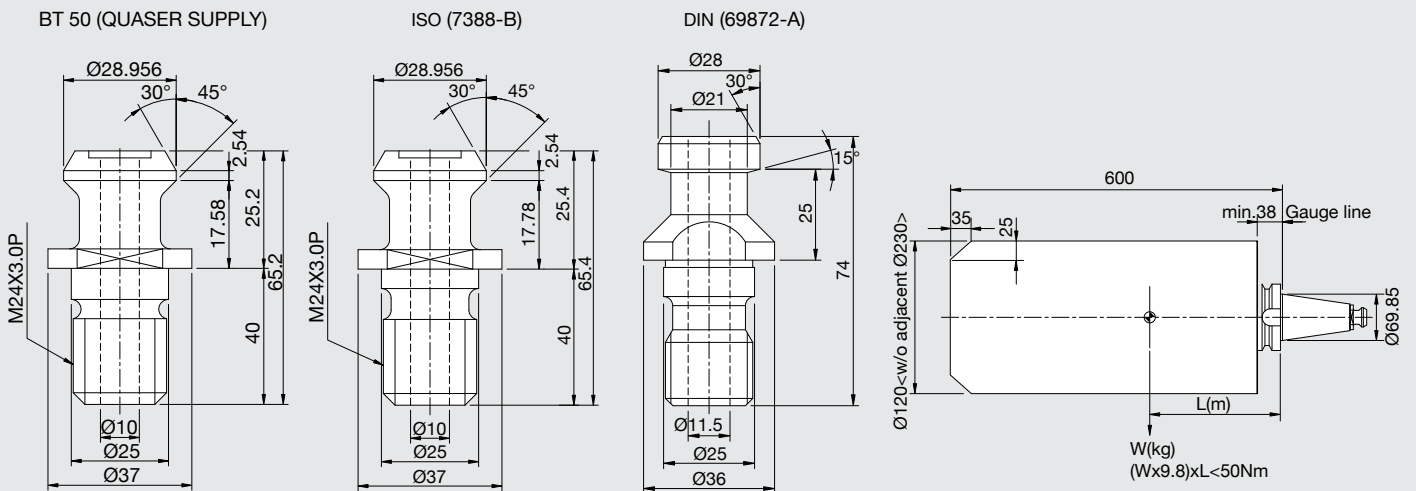



www.quaser.com

Fold here for filing!

08012805 **MaCIS** TEL 04-2473326